

Tiger-Vac®

...The name to vacuum with

INDUSTRIAL VACUUM CLEANER SYSTEMS
ELECTRICALLY OPERATED THREE PHASE FOR CONTINUOUS DUTY
MODELS ETD-11 DT (MRP) and ETD-11 DT (MFS)



ETD-11 DT (MRP)



ETD-11 DT (MFS)



Rear View

- Regenerative blower with TEFC induction motor rated for continuous duty
- Portable recovery unit, support cart assembly with 4 sturdy wheels
- Heavy duty powder coated steel construction
- Class 1611 01 & 1611 81 - cleaning machines. All the electrical components are recognized or certified UL or CSA and meet all applicable requirements. CAN/CSA-C22.2 No. 243-01 ANSI/UL STD. No. 1017

DESIGN APPLICATION

- High Performance - Low Cost
- Liquids can be recovered into a separate primary recovery tank
- Detachable recovery tank: dry only, 10 gallons (40 litres)
- Suction orifice: Ø2" (Ø50mm)
- Environments where ultra-fine dusts such as cement, drywall, masonry powders, sanding & grinding are present and need to be recovered continuously.
- Applications with dustless tools for point of generation dust control.

Toll free telephone: 1 800 668-4437

Toll free fax: 1 800 668-4439

Tiger-Vac Inc. (USA)
73 S.W. 12 Ave. Bldg.1, Unit 7
Dania, FL 33004
USA

Tel.: (954) 925-3625

Fax.: (954) 925-3626

E-mail: sales@tiger-vac.com

Web Site: <http://www.tiger-vac.com>

Tiger-Vac International Inc.
2020 Dagenais Blvd. West
Laval, Quebec
Canada H7L 5W2

Tel.: (450) 622-0100

Fax.: (450) 625-3388

E-mail: support@tiger-vac.com

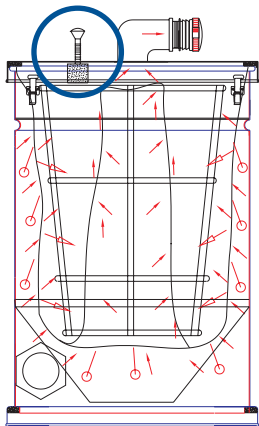

MANUAL FILTER SHAKER SYSTEM (MFS)

- The filter shaker system consists of a spring action mechanism operating directly onto the filter cage located inside of the filter chamber. The system is operated by pressing on the ergonomic handle located on the top the filter chamber.
- The Manual Filter Shaker dislodges the accumulated caked-on dust from the filter thus improving the filter's performance.
- The filter, along with the filter cage, can be easily removed from the filter chamber and washed with lukewarm water and mild detergents.
- The reusable (washable) polyester filter has a surface area of 5 ft² (5 110 cm²).

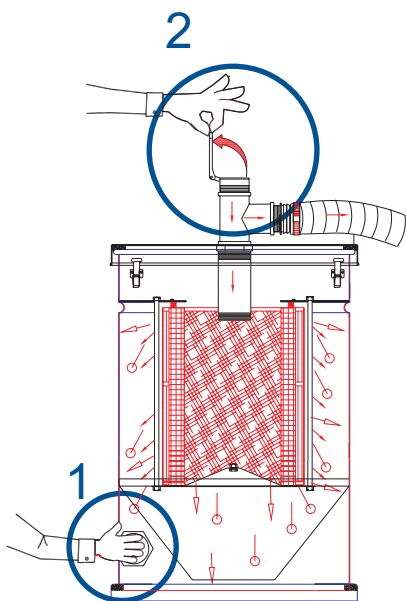

MANUAL REVERSE PURGE SYSTEM (MRP)

- The Manual Reverse Purge (MRP) allows for the cleaning of caked-on powder off of the filter thus maximizing performance. The filter cleaning is achieved by having the air intake reversed through the filter thus purging the clogged filter.
- The Manual Reverse Purge (MRP) works by :
 - ① Placing a hand over the opening to block the suction intake orifice for approximately 5 seconds while the vacuum is running. (No.1)
 - ② Then quickly open Purge Valve (No.2). Air is now flowing via the valve through to the filter.
 - ③ Keep Purge Valve open for 1-2 seconds then close (repeat above steps 2 or 3 times).
- Reverse Purge System will cause dust to fall off of the filter.
- The filter cartridge is made of polyester and has a surface area of 40 ft² (37 161 cm²)

SPECIFICATIONS

Voltage (3 Phase)	Power	Airflow (max)	Vacuum (max)	VRV set at
460V / 60 Hz	1.9 Kw/ 2.5 HP	140 cfm	111"+ H2O	80" H2O
460V / 60 Hz	2.6 Kw/ 3.5 HP	219 cfm	145"+ H2O	110" H2O
575V / 60 Hz	2.6 Kw/ 3.5 HP	219 cfm	145"+ H2O	110" H2O

For complete details please visit our website: WWW.TIGER-VAC.COM or contact one of our technical representatives.

Specifications are subject to change without notice. Tiger-Vac is a registered trademark.