

AS-400 HEPA

Industrial vacuum cleaner systems

Electrically operated

Models AS-400 HEPA and AS-400 MR HEPA

HEPA filter efficiency of 99.99% on 0.3 micron



Left: AS-400 (HEPA), poly and stainless steel tank.

Right: AS-400 (HEPA) MR, poly and stainless steel tank

Characteristics:



HEPA filter



Low noise level



- Powerful suction – designed for industrial applications.
- Lightweight and ergonomic.
- Three-stage filtration system.
- Ready to use : Includes HEPA filter and tool kit.
- Convenient design allows easy access to HEPA Filter while maintaining leak proof seal
- Very silent: only 63 dB(A).
- Available with polypropylene recovery tank or with stainless steel (AISI 430) recovery tank.
- Available with stainless steel middle-ring (AISI 430) for wet and dry recovery.



Tiger-Vac®

...The name to vacuum with

Tiger-Vac Inc. (USA)
73 S.W. 12 Ave. Bldg. 1, Unit 7
Dania, FL 33004
USA

Tel.: (954) 925-3625

Fax.: (954) 925-3626

E-mail: sales@tiger-vac.com

Tiger-Vac International Inc.

2020 Dagenais Blvd. West

Laval, Quebec

Canada H7L 5W2

Tel.: (450) 622-0100

Fax.: (450) 625-3388

E-mail: support@tiger-vac.com

Toll free telephone: 1 800 668-4437 (Fax: 1 800 668-4439)

<http://www.tiger-vac.com>

Performance chart

Model	Voltage	Electric power	Airflow	Vacuum at sealed orifice	Recovery capacity - bag	Recovery capacity - tank
AS-400 HEPA	120V	1200 W	120 CFM	93" H ₂ O	5 Gal	10 gal
	220/240V	1200 W	63 l/s	2140mm H ₂ O	5 Gal	10 gal
Dimensions:	Poly tank: 20.5" X 19.5" X 33", 33lbs (525mm X 495mm X 838mm, 15kg). Power cord: 33' (10m).					Noise level: Only 63dB(A)
	Stainless steel tank: 20.5" X 19.5" X 33", 34lbs (525mm X 495mm X 838mm, 15.5kg). Power cord: 33' (10m).					Noise level: Only 63dB(A)
AS-400 MR HEPA	120V	1200 W	120 CFM	93" H ₂ O	5 Gal	10 gal
	220/240V	1200 W	63 l/s	2140mm H ₂ O	5 Gal	10 gal
Dimensions:	Poly tank: 20.5" X 19.5" X 38", 41lbs (525mm X 495mm X 965mm, 18.5kg). Power cord: 33' (10m).					Noise level: Only 63dB(A)
	Stainless steel tank: 20.5" X 19.5" X 38", 42lbs (525mm X 495mm X 965mm, 19kg). Power cord: 33' (10m).					Noise level: Only 63dB(A)

FILTRATION AND SYSTEM OVERVIEW

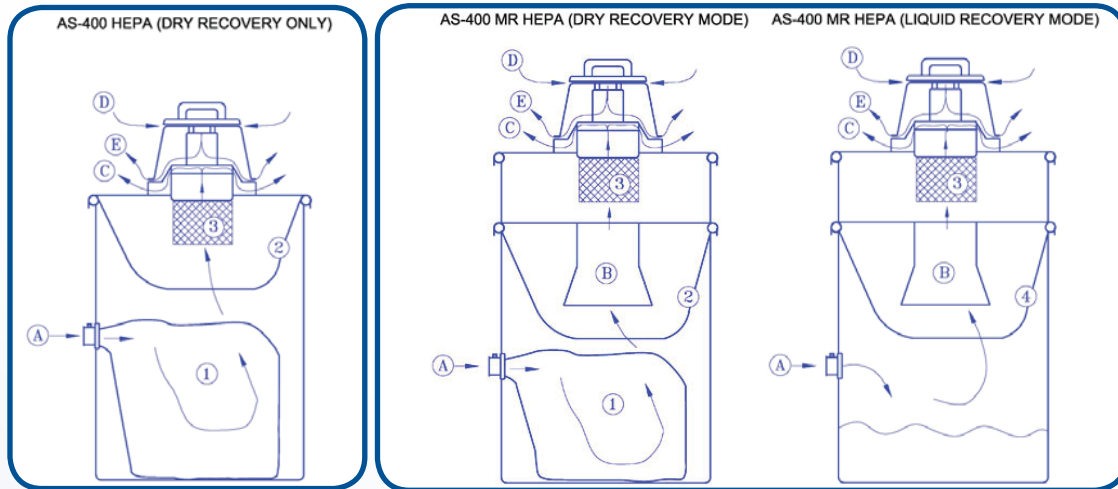

FILTRATION SYSTEM:

1. **PAPER FILTER BAG:** The disposable paper filter bag collects the bulk of the recovered materials and facilitates disposal
2. **MAIN CLOTH FILTER:** the washable main cloth filter protects the HEPA filter from clogging dust
3. **HEPA FILTER:** Minimum filtration efficiency of 99.99% on 0.3 micron; captures ultra-fine dust (toxic and nuisance)
4. **LIQUID FILTER:** Made of polypropylene mesh.

SYSTEM OVERVIEW:

- A. **SUCTION INTAKE**
- B. **FLOATER:** Cuts off suction when recovered liquids reach capacity limit
- C. **FILTERED WORKING AIR EXHAUST**
- D. **MOTOR COOLING AIR INTAKE**
- E. **MOTOR COOLING AIR EXHAUST**

INCLUDED Ø1.5" (38mm) TOOLS AND ACCESSORIES

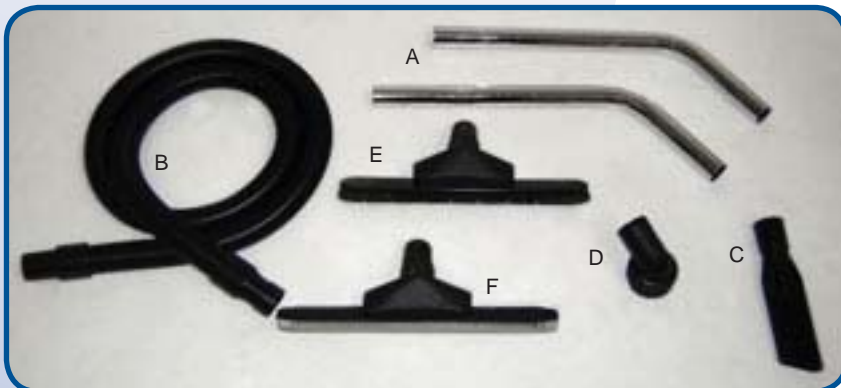

- | | | |
|---|---------|---------------------------------------|
| A. | 381163A | Double bend wand (2pc) 54" (1.37m) |
| B. | 381475 | Crushproof suction hose 8' (2.65m) |
| C. | 381480 | Crevice tool 10" (25cm) |
| D. | 381482 | Dusting brush 3" (76mm) |
| E. | 381485 | Floor tool with bristles 16" (40.7cm) |
| Included with AS-400 MR HEPA only: | | |
| F. | 381490 | Squeegee floor tool 16" (40.7cm) |



All AS-400 models are mounted on an ergonomic carriage base with onboard storage area for the accessories.

For complete details please visit our website: WWW.TIGER-VAC.COM or contact one of our technical representatives.

Specifications are subject to change without notice. Images are for illustration purposes only. Tiger-Vac is a registered trademark.